

MAINTENANCE PARTS FOR BAK-PAK® SPRAYERS 1995 AND LATER

MODELS: 6635 63183 63184

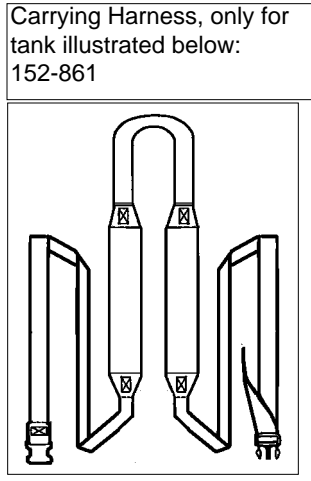

X-Pert Viton®
Maintenance Kit: 9391
only parts marked §
are Viton
Suprema Maintenan-
ce Kit: 6944

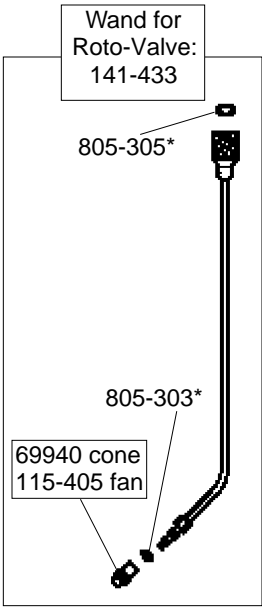
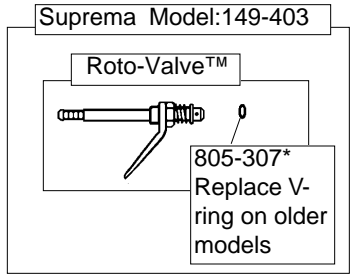
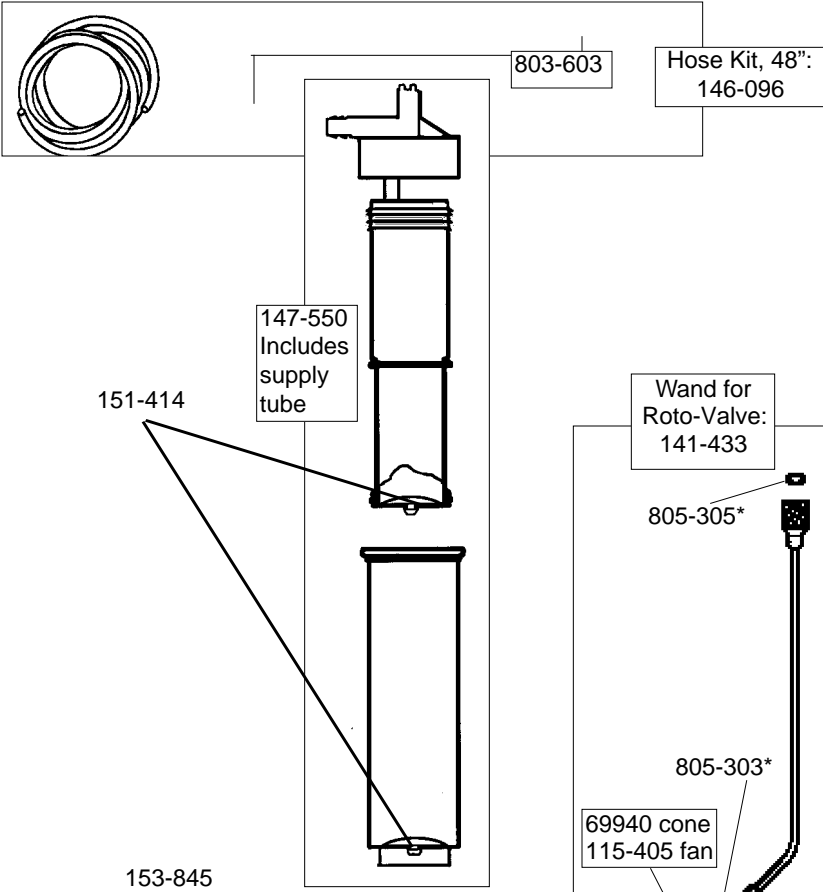

Parts marked with *
included in
Maintenance Kit.

